

# PASSAGE SUBSCRIBER SOCKET NAP-9/NT

# ZAMEL

Zakład Mechaniki i Elektroniki  
**ZAMEL** sp.j.

J.W. Dzida, K. Łodzińska

ul. Zielona 27, 43-200 Pszczyna, Poland

Tel. +48 (32) 210 46 65, Fax +48 (32) 210 80 04

[www.zamelcet.com](http://www.zamelcet.com), e-mail: [marketing@zamel.pl](mailto:marketing@zamel.pl)

## APPEARANCE

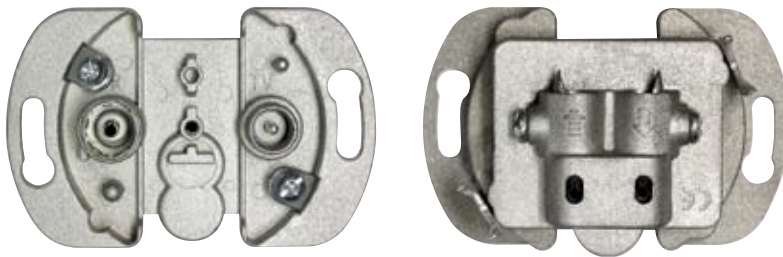

CE **A** CLASS

## DESCRIPTION

- Designed for analogue and digital RTV installations,
- passage socket for aerial systems of a star-shaped type or individual aerial RTV installations,
- two ports: input and output, for coaxial conductor conducting signal to and from in the frequency of 5÷862 MHz,
- two output ports consistent with standard IEC 60169-2 to connect radio receiver "R" and TV receiver "TV",
- usage of the frequency ranges of bands TV, R,
- full characteristic of transmission in particular bands,
- high separation between particular ports,
- galvanic separation of input from TV and R outputs,
- reliability and repeated nature of parameters, thanks to the performance in the SMT technology,
- casing of high screening efficiency made of ZnAl alloy.

## CERTIFICATES

On the basis of the document: TECHNICAL ASSESSMENT No Nr 470/2003 of the Institute of Communications, the socket NAP-9/NT fulfils the basic requirements stipulated in standards:

- PN-EN 50083:2003 Cable networks intended for signal transmissions: TV, radio and interactive services. Part 2: Electromagnetic Compatibility of Appliances. Chapter: 5.4, Table 8, Class A;
- PN-EN 50083:2002 Cable networks intended for signal transmissions: TV, radio and interactive services. Part 4: Passive broadband appliances for coaxial cable networks. Chapter: 5.3,
- PN-EN 60728-11:2005(U) Cable networks intended for signal transmissions: TV, radio and multimedia services. Part 11: Safety requirements. Chapters: 10.2, 10.3.

		5	70	88	108	120	174	230	470	862 MHz
		RETURN B1	FM			LOW S bottom special band S2+S8	B III VHF III K06+K12	HIGH S hyperband top special band S9+S38	UHF K21+K69	
Coupling attenuation	IN→R	-	9,5 dB			-	-	-	-	
	IN→TV	9,5 dB	-			9 dB	8,5 dB	8,5 dB	8,5 dB	
	IN→OUT	3,5 dB	3 dB			3 dB	3 dB	3 dB	3 dB	
Not fitting attenuation	R	-	11 dB			-	-	-	-	
	TV	12 dB	-			16 dB	15 dB	15 dB	10 dB	
	IN	22 dB	20 dB			19 dB	18 dB	18 dB	16 dB	
	OUT	23 dB	19 dB			18 dB	17 dB	16 dB	14 dB	
Screening coefficient		83 dB		83 dB		83 dB	82 dB	82 dB	81 dB	
Cross-talk attenuation R→TV		≥12,2 dB								
Wave impedance IN, OUT		75 Ω								

CHARACTERISTICS

SCHEME

Coupling attenuation IN→OUT

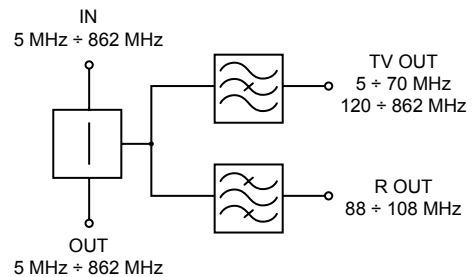
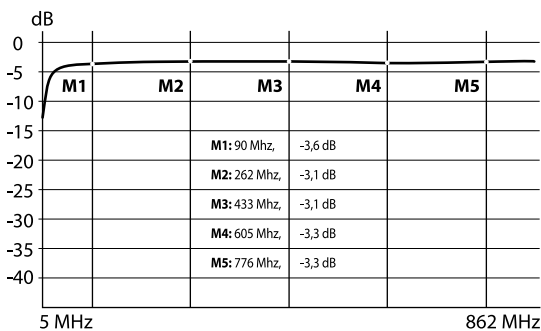

Coupling attenuation IN→TV

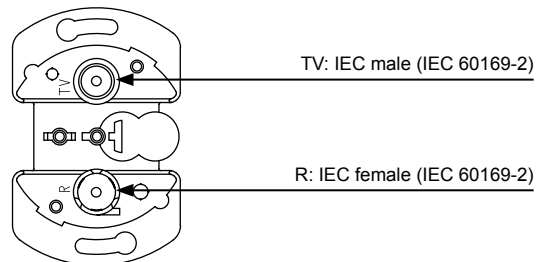
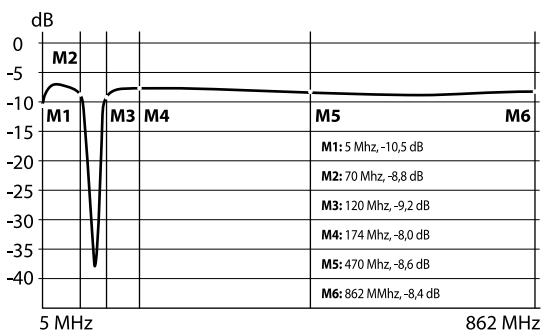

Coupling attenuation IN→R

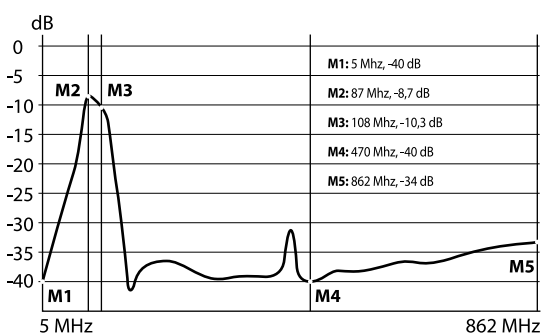

MEASUREMENTS

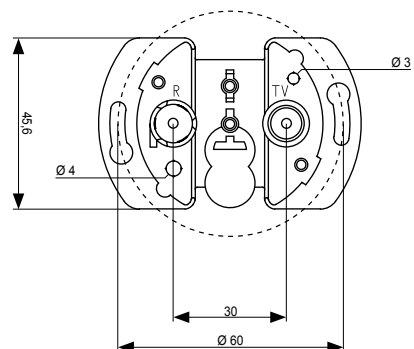

1. Prepare end of aerial conductor for connection, i. e. insulate conductor of concentric cable, cutting off external insulation, plait and cable core at the same length (illus. 1).
2. Unscrew set screw in input socket (illus. 2).
3. Put aerial conductor into it, so that socket point would go between plait and external insulation. The correctness of putting conductor of cable into input clamp should be checked (illus. 4).
4. Screw home set screw in input socket (illus. 5).
5. For output socket, the manner of action is analogous to that for input socket,
6. Put socket into installation box, size  $\text{Ø}60$  mm and depending on kind of socket, fix it with clamps or fixing tap screws.
7. Put on frame with cover on socket body.

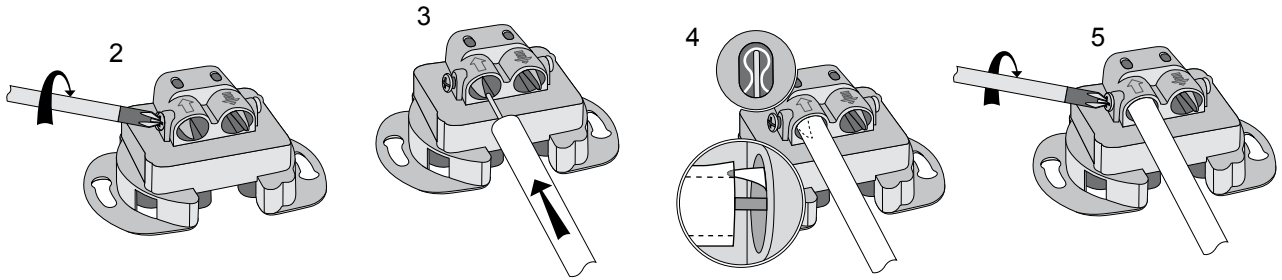
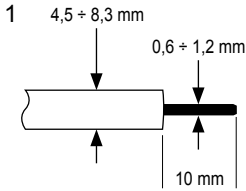

**EXEMPLARY APPLICATION**

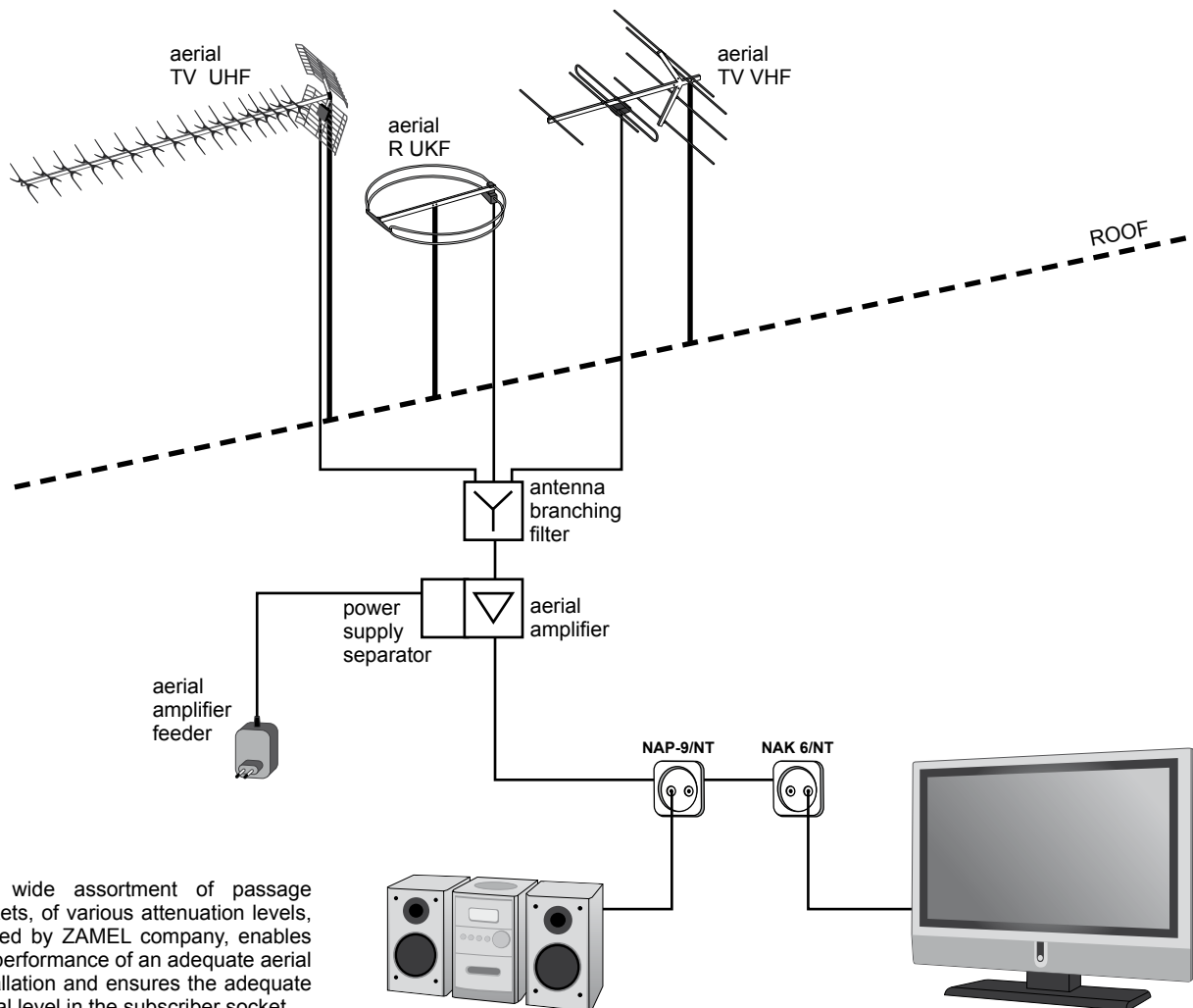

The wide assortment of passage sockets, of various attenuation levels, offered by ZAMEL company, enables the performance of an adequate aerial installation and ensures the adequate signal level in the subscriber socket.