

FINAL SATTELITE SOCKET NAR-SAT 3.1/NT



Zakład Mechaniki i Elektroniki
ZAMEL sp.j.

J.W. Dzida, K. Łodzińska

ul. Zielona 27, 43-200 Pszczyna, Poland
Tel. +48 (32) 210 46 65, Fax +48 (32) 210 80 04
www.zamelcet.com, e-mail: marketing@zamel.pl

APPEARANCE

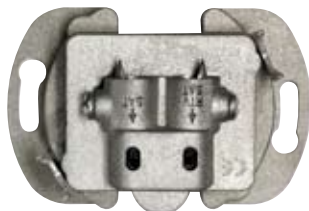
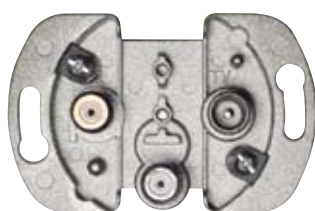

CE A CLASS

DESCRIPTION

- Designed for analogue and digital RTV-SAT installations,
- useful for N TV N-box decoders, where two Hotbird signals are needed or for double stream CI modules,
- two output ports for HF coaxial cables: 5 ÷ 2400 MHz for SAT input, 5 ÷ 2400 MHz for RTV/SAT input,
- high separation between particular ports,
- the possibility of usage of SAT port as reversible channel,
- galvanic separation of input from R outputsTV,
- reliability and repeated nature of parameters, thanks to the performance in the SMT technology,
- casing of high screening efficiency made of the ZnAl alloy.

CERTIFICATES

On the basis of the document: TECHNICAL ASSESSMENT No 042/2008 of the Institute of Communications, the socket ZAR-SAT 3.1/P1 fulfils the basic requirements stipulated in standards:

- PN-EN 50083:2003 Cable networks intended for signal transmissions: TV, radio and interactive services. Part 2: Electromagnetic Compatibility of Appliances. Chapter: 5.4, Table 8, Class A;
- PN-EN 50083:2002 Cable networks intended for signal transmissions: TV, radio and interactive services. Part 4: Passive broadband appliances for coaxial cable networks. Chapter: 5.3,
- PN-EN 50083:2008 Cable networks intended for signal transmissions: TV, radio and multimedia services. Part 10: Safety requirements. Chapter: 10.2.4.

		5	70	88	108	120	174	230	470	862	950	2150	2400 MHz
		RETURN B1	FM		LOW S bottom special band S2+S8	B III VHF III K06+K12	HIGH S hyperband top special band S9+S38	UHF K21+K69		SAT IF		SAT IF broadened	
Coupling attenuation	RTV/SAT → RTV	0,5 dB	0,5 dB		0,5 dB	0,5 dB	0,5 dB	1,5 dB		-		-	
	RTV/SAT → SAT1	-	-		-	-	-	-		1,5 dB		1,5 dB	
	SAT → SAT2	0,5 dB	0,5 dB		0,5 dB	0,5 dB	0,5 dB	0,5 dB		0,5 dB		1,5 dB	
Not fitting attenuation	RTV	21 dB	19 dB		19 dB	13 dB	11 dB	11 dB		-		-	
	SAT1	-	-		-	-	-	-		11 dB		7 dB	
	SAT2	44 dB	33 dB		24 dB	24 dB	17 dB	12 dB		10 dB		6 dB	
	IN RTV/SAT	22 dB	19 dB		19 dB	19 dB	12 dB	11 dB		10 dB		6 dB	
	IN SAT	51 dB	35 dB		35 dB	24 dB	17 dB	11 dB		10 dB		6 dB	
Screening coefficient		≥92 dB											
Cross-talk attenuation	OUT SAT1 ↔ RTV	ap _{min} = 25,3 dB											
	IN SAT ↔ RTV/SAT	ap _{min} = 11,6 dB											
Wave impedance IN, OUT		75 Ω											

CHARACTERISTICS

SCHEME

Coupling attenuation RTV/SAT → RTV

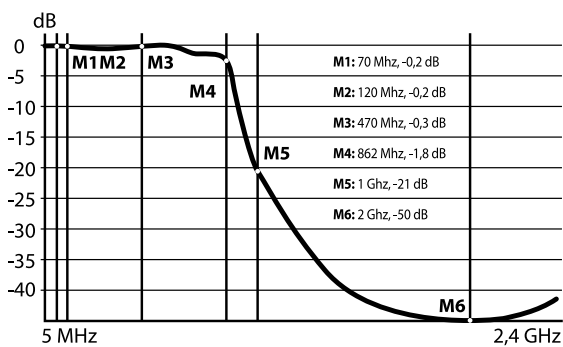

Coupling attenuation RTV/SAT → SAT1

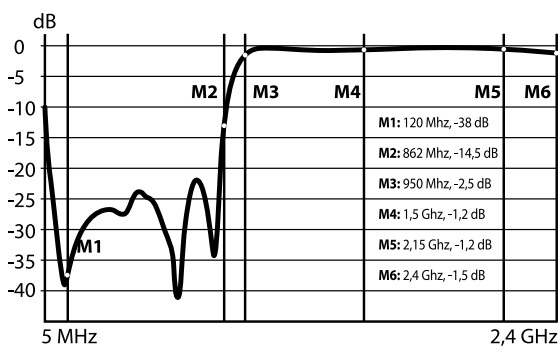

Coupling attenuation SAT → SAT2

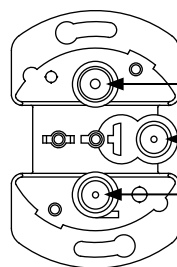
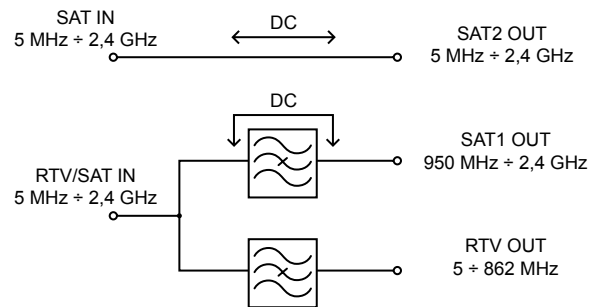
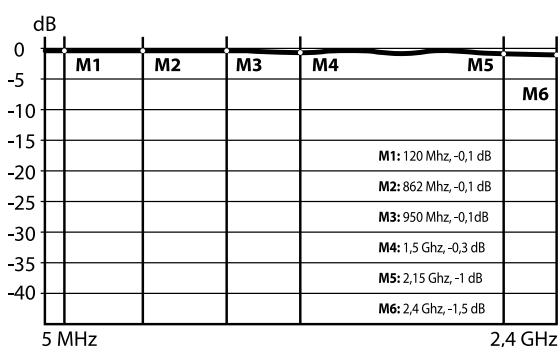

RTV (5 MHz + 862 MHz): IEC male (IEC 60169-2)

SAT2 (5 MHz + 2,4 GHz): F female (IEC 60169-24)

SAT1 (950 MHz + 2,4 GHz): F female (IEC 60169-24)

MEASUREMENTS

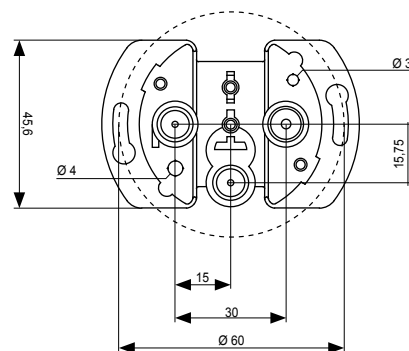

1. Prepare end of aerial conductor for connection, i. e. insulate conductor of concentric cable, cutting off external insulation, plait and cable core at the same length (illus.1).
2. Unscrew set screw in input socket (illus. 2).
3. Put aerial conductor into it, so that socket point would go between plait and external insulation. The correctness of putting conductor of cable into input clamp should be checked (illus. 4).
4. Screw home set screw in input socket (illus. 5).
5. For next input socket, the manner of action is analogous to that for first input socket,
6. Put socket into installation box, size $\varnothing 60$ mm and depending on kind of socket, fix it with clamps or fixing tap screws.
7. Put on frame with cover on socket body.

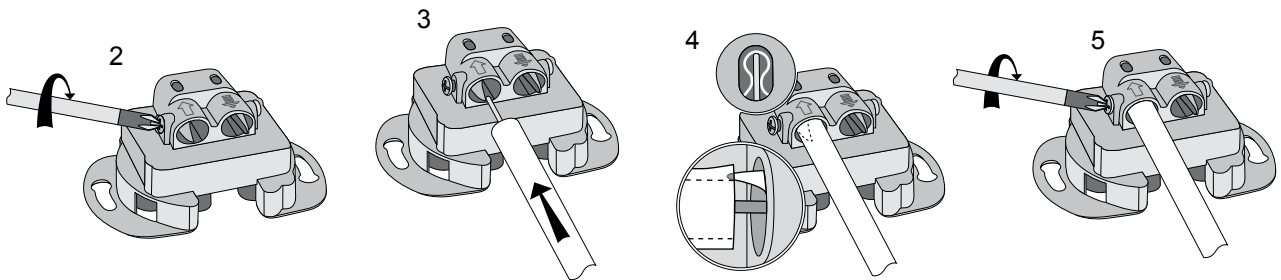
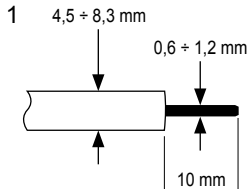

EXEMPLARY APPLICATION

